

Chemin de câble fil + GRSM.6
(Mesh tray +GRSM.6)

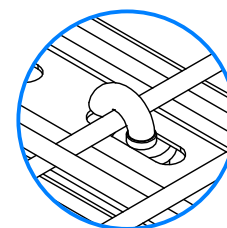

Description	Code	Masse/Weight Kg/p	Ep./Th. mm	H mm	l./w. mm	 daN
N 0 SZ	011001	0,11	1,00	93	150	25

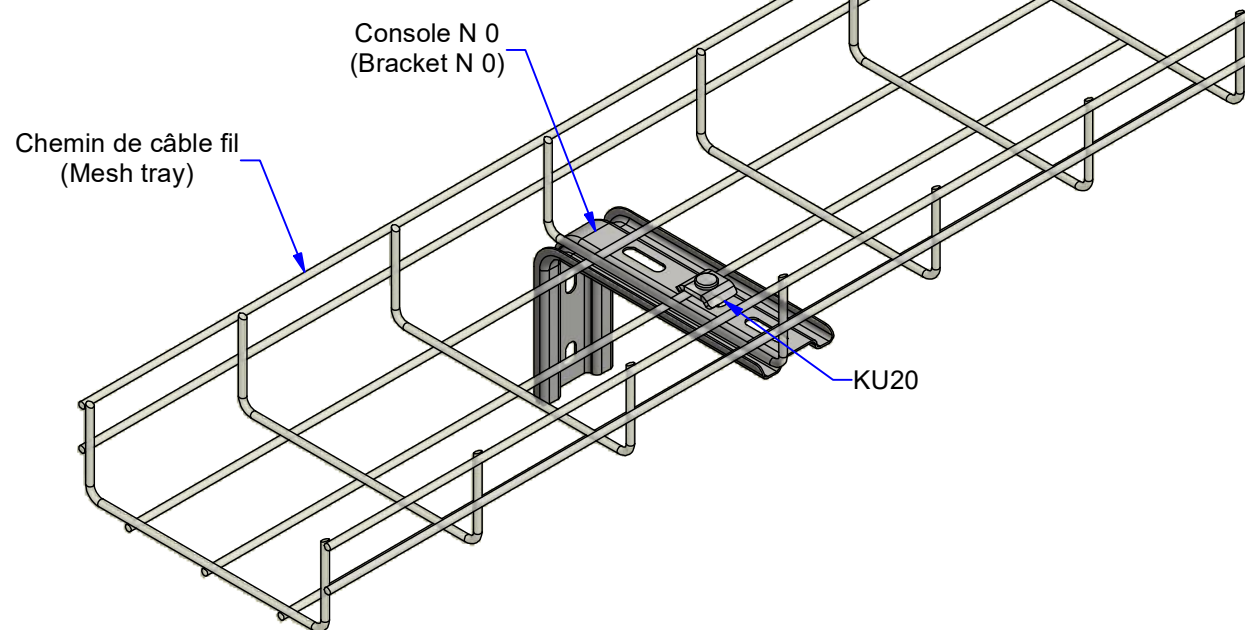

G : Pre-galvanised according to NF EN 10346 (S220 GD / Z).

SZ : Tôle d'acier galvanisé avant fabrication suivant NF EN 10346 (S220 GD / Z).



www.niedaxfrance.fr

<p>CONSOLE N 0 SZ BRACKET N 0 G</p>		
<p>ASSISTANCE TECHNIQUE +33 (0)1 55 95 92 17 pole.technique@niedax.fr</p>		
<p>FT02101</p>		